

BENDIX® AD-HF® AIR DRYER

The new industry-standard for full-function air dryers

Designed with Fleets in Mind

We understand that reduced maintenance and lowest total cost of ownership (TCO) are critical to your fleet. When we designed the Bendix® AD-HF®, our newest, full-function air dryer, we asked fleets what was important to them.

The innovative AD-HF air dryer delivers high-reliability with low-weight including an integrated purge reservoir. Engineered to maximize service life, the Bendix AD-HF features improved corrosion resistance and is easy to service. A Bendix® PuraGuard® oil coalescing air dryer cartridge is now standard.

Reduced Weight

We applied advanced engineering tools to design a high strength, two-piece aluminum casting with lower internal pressure drops. Weighing in at eight pounds lighter than the Bendix® AD-IS® dryer, the standard AD-HF air dryer was designed to help you achieve your weight reduction goals.

A two-piece housing is secured with both a retaining band and a sealed center-bolt. Our AD-HF dryer is also available with an integrated extended purge reservoir. Purge reservoirs are pressure rated in accordance with SAE J10 requirements.

Improved Corrosion Resistance

A corrosion resistant housing extends the service life of the dryer when subjected to harsh road surface treatments. The primary housing is also treated with an additional layer of corrosion protection. The robust housing and reservoir also enable high-quality remanufacturing by Bendix.

Easy to Service

No one wants to replace an entire air dryer due to a single component failure. That's why the Bendix AD-HF incorporates patented field serviceable pressure protection valves (PPVs) that can be replaced in less than two minutes. Trucks often require a variety of plumbing variations, so the AD-HF model has additional ports and improved port spacing that make it easier for technicians to install fittings and turn wrenches.

Additionally, the AD-HF unit features the industry standard Bendix® D2® style governor. Combine that with common service components to the Bendix AD-IS – including the purge valve and heater – and you can stock fewer parts to support a wider variety of trucks.



BENDIX® AD-HF® AIR DRYER

100% Oil Coalescing Cartridge

The Bendix® AD-HF® dryer was designed around PuraGuard® oil-coalescing technology. PuraGuard filtration removes harmful oil aerosols and helps prevent costly component failures that rely on clean, dry air. Featuring a new 41 mm spin-on mounting thread, our patented AD-HF model is designed to prevent replacement with non-oil coalescing aftermarket cartridges.

Industry Leading Warranty with Bendix® Total Air Guarantee

Any new truck supplied with a Bendix AD-HF air dryer is eligible for the Bendix Total Air Guarantee (TAG) warranty. TAG extends the warranty of Bendix air brake valves, including ABS, for 3 years or 350,000 miles when installed as original equipment on the same vehicle. Download BW1716 from the Bendix document library on bendix.com for additional details.

AD-HF® Air Dryer Specifications:

Envelope:	11.3" H x 10.5" W x 11.7" D
Weight:	Standard purge: 19 pounds Extended purge: 21 pounds
Heater:	12V or 24V
Purge volume:	Standard purge: 200 in ³ Extended purge: 300 in ³
Mounting:	SAE 4-hole thread pattern 3/8"-16 UNC bolts
Governor:	D2® style with 3 pressure ranges available
Warranty:	3 years/350,000 miles*
Turbo cut-off valve:	Optional
Cartridge replacement:	Bendix part number 5009041PG
Cartridge service interval:	See Bendix service data sheet SD-08-12046

**Spin-on cartridge, purge valve and pressure protection valves are considered service items that may need to be replaced during normal operation. Standard warranty policies apply.*

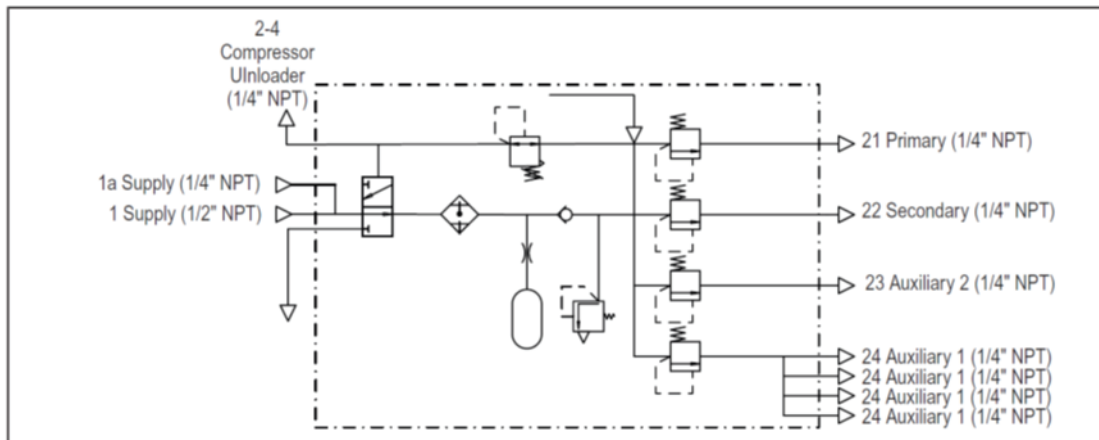

Bendix® AD-HF™ schematic

Protect your investment with the name you know and the brand you trust.

The Bendix® AD-HF® air dryer is the highest performance air supply solution for commercial vehicles. For more information, contact your Bendix Account Manager, call 1-800-AIR-BRAKE or visit bendix.com.